

# GARAGE CONVERSION

## SUBMITAL REQUIREMENTS

California Code Editions: 2022 CRC, CEC, CPC, CMC, Energy Codes

### Your Submittal for a Building Permit must include the following information:

1. Fill out a Building Permit Application.
2. Provide three (3) copies of construction plans, (see attached for an example of plans) or provide professional drawings.
3. Provide three (3) copies of a floor plan showing the location of garage and all other rooms, (see attached for an example).

### Garage Conversion Requirements:

1. Garage conversions must comply with all Planning requirements.
2. The garage door is to be removed and a framing detail will be required. (see attached for an example)
3. Include all electrical, plumbing and mechanical:
  - a). Electrical to comply with the CEC, including but not limited to sections: 210.12 (A) AFCI's and 210.50 required outlets, 406.12 'Tamper-Resistant' receptacles.
  - b). Plumbing to comply with the CPC.
  - c). Mechanical to comply with the CMC.
4. Concrete floors must be sealed with an approved vapor barrier sealer.
5. All exterior walls to be insulated with min. R-13 for 2x4 framing and R-19 for 2x6 framing.
6. Ceilings to be insulated with min. R-38 (two batts of R-19), or per energy calcs.
7. If the conversion is to include a new bedroom(s):
  - a). Emergency escape and rescue openings will be required out of each bedroom: Section R310 of the CRC.
  - b). Each new and existing bedroom will require a smoke alarm with battery backup and a smoke and carbon monoxide alarm in the rooms leading to the bedrooms. CRC R314 and R315.
8. Light and ventilation shall comply with section R303.1 of the CRC. A minimum of 8% natural lighting. 4% natural ventilation of floor area is required, as well as mechanical venting in bathrooms per the 2019 CMC.

# FLOOR PLAN

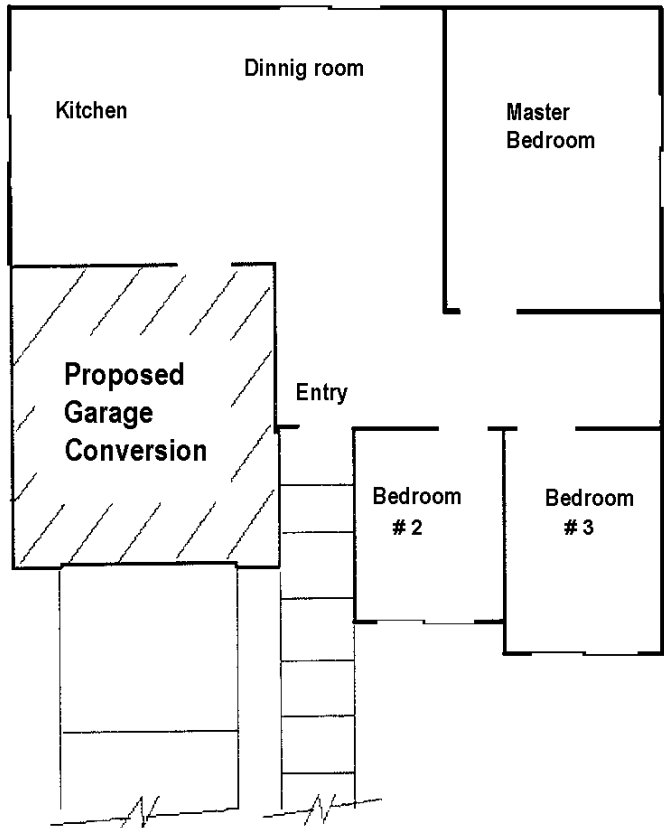

# Sample Layout of Conversion

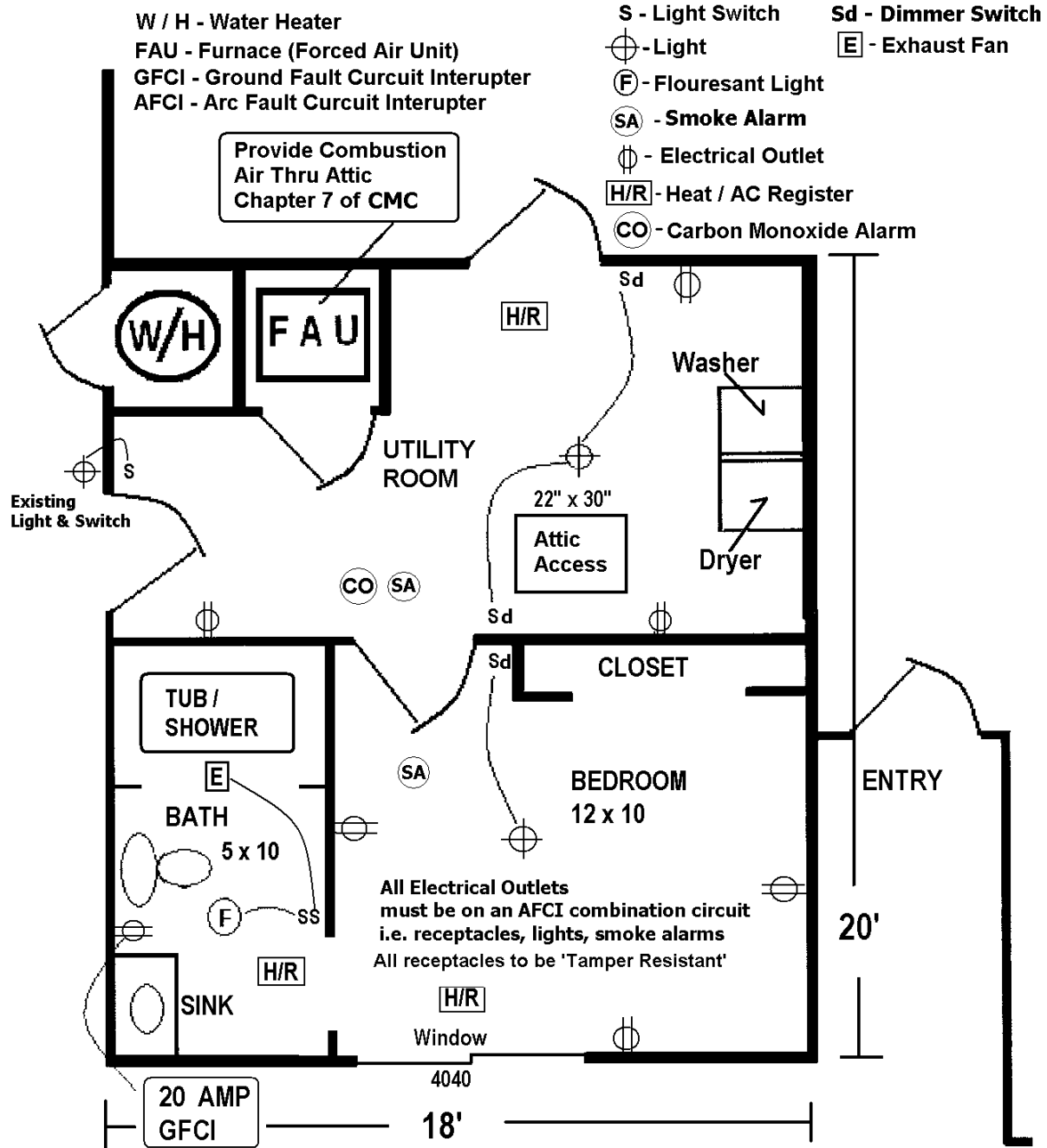

## Sample Detail of Garage Wall Framing

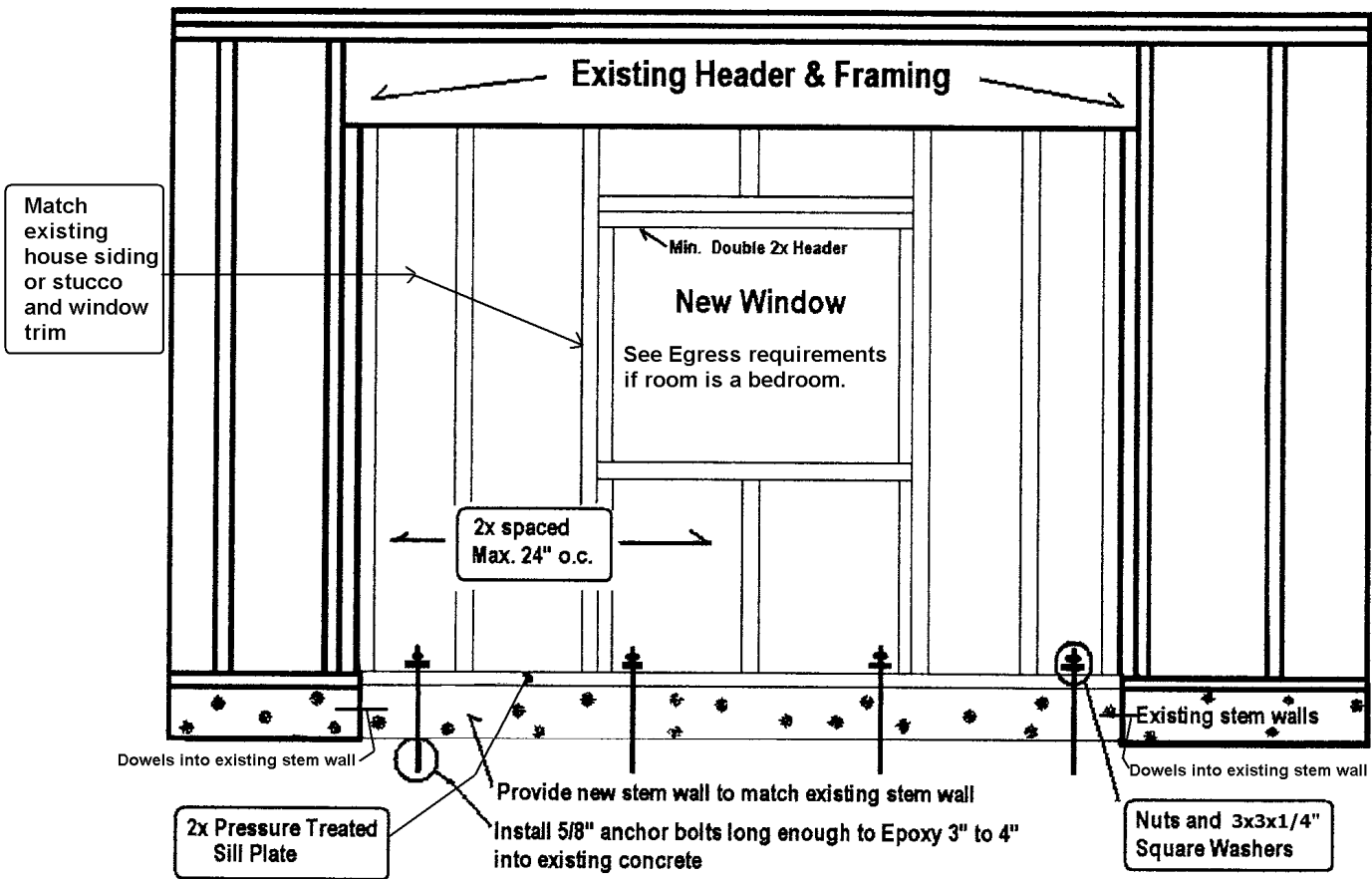

### Emergency Escape and Rescue Window Required in Bedrooms

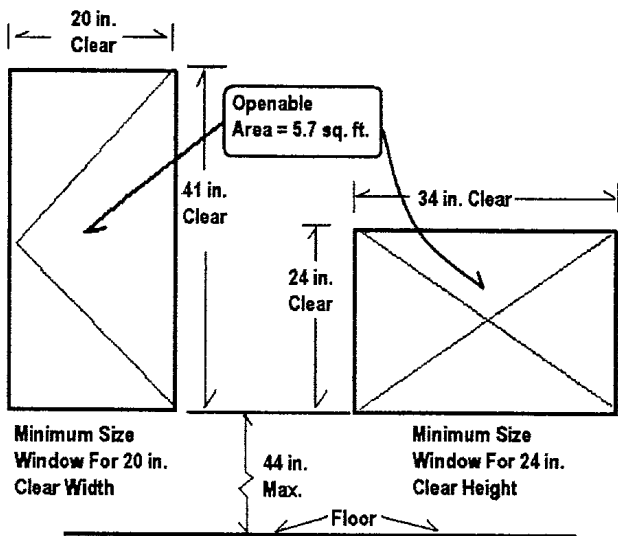

### Schedule of Inspections

- 1st - Under slab plumbing (if needed)
- 2nd - Stem wall forms (may be combined with under slab plumbing).
- 3rd - Frame: Including all new internal walls and garage wall. Rough electrical. Rough plumbing. Rough mechanical. Lath nailing should be completed if exterior finish is stucco.
- 4th - Insulation
- 5th - Sheetrock nailing. Completed lath if stucco.
- 6th - Final: Everything is complete and ready to use.